

# 4WD (w/ 2-4 SELECT SW)

FROM POWER SOURCE SYSTEM (SEE PAGE 48)

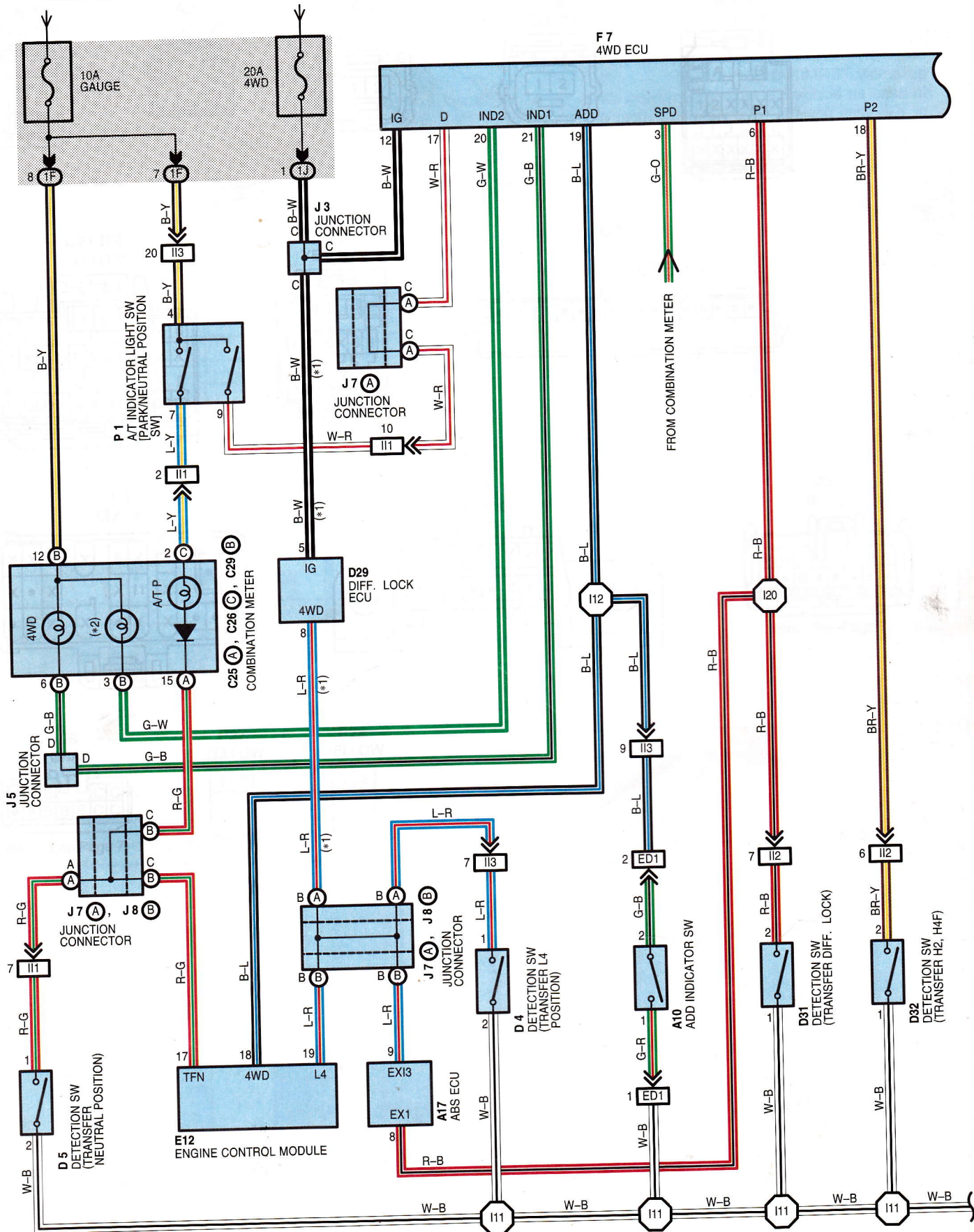

- \* 1 : W/ REAR DIFF. LOCK
- \* 2 : CENTER DIFF. LOCK

F7  
4WD ECU

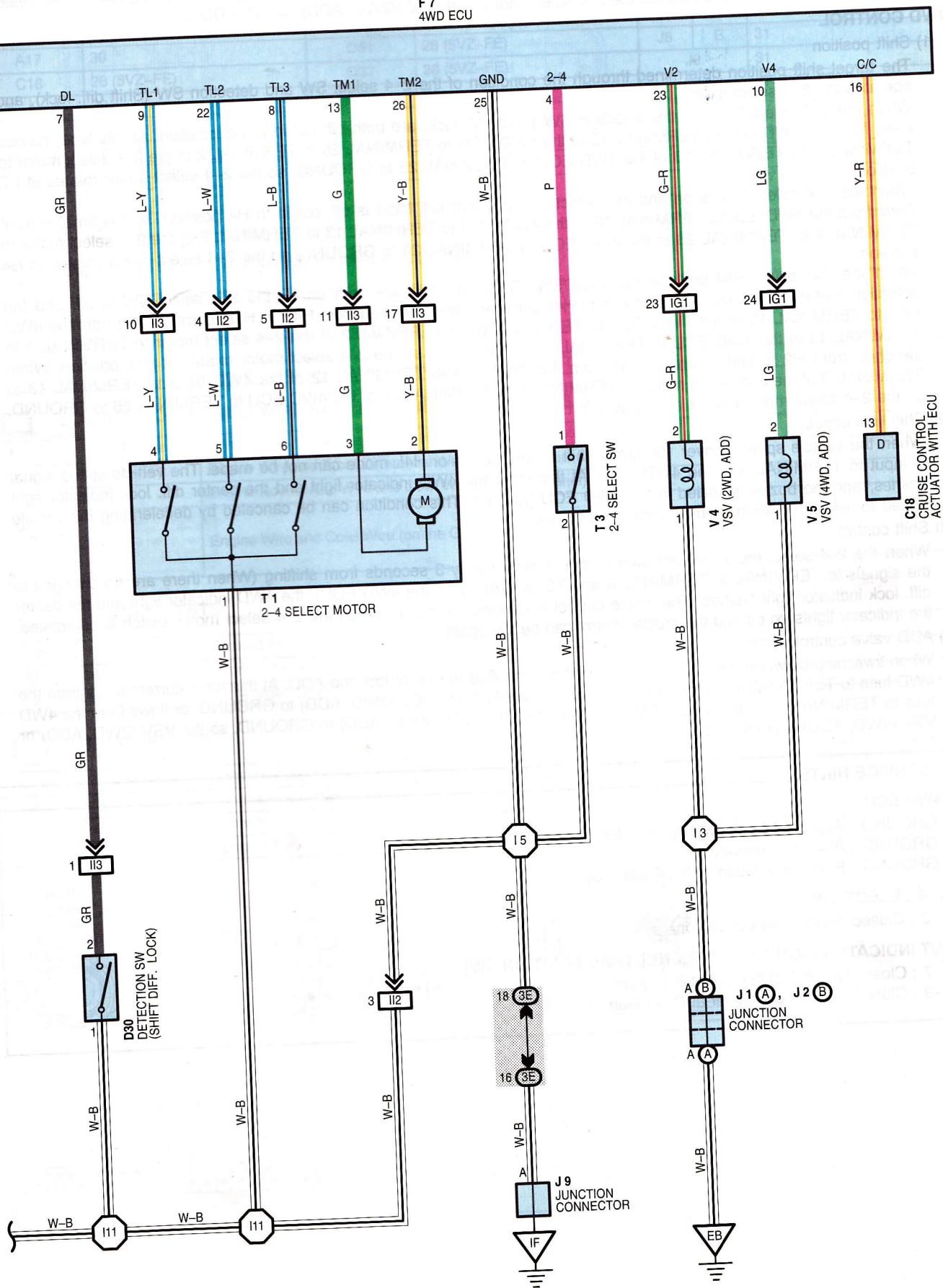

## 4WD (w/ 2-4 SELECT SW)

### SYSTEM OUTLINE

The 4WD ECU detects the condition of the detection SW ((Shift diff lock), (Transfer diff. lock), (Transfer H2, H4F)), 2-4 select SW and the vehicle speed, and controls the 2-4 select motor and VSV ((2WD, ADD), (4WD, ADD)).

### 4WD CONTROL

#### (1) Shift position

The target shift position determined through the condition of the 2-4 select SW and detection SW (Shift diff. lock), and operates the 2-4 select motor.

- \* When the 2-4 select SW and the detection SW (Shift diff. lock) are both off, put in to H2 position. At this time, current flows from the 4WD fuse to TERMINAL 12 of the 4WD ECU to TERMINAL 26 to TERMINAL 2 of the 2-4 select motor to TERMINAL 3 to TERMINAL 13 of the 4WD ECU to TERMINAL 25 to GROUND, so the 2-4 select motor rotates at H2 position.
- \* When the 2-4 select SW is on and the detection SW (Shift diff. lock) is off, put in to H4 position. At this time, current flows from the 4WD fuse to TERMINAL 12 of the 4WD ECU to TERMINAL 13 to TERMINAL 3 of the 2-4 select motor to TERMINAL 2 to TERMINAL 26 of the 4WD ECU to TERMINAL 25 to GROUND, so the 2-4 select motor rotates at H4 position.
- \* When the 2-4 select SW and the detection SW (Shift diff. lock) are both on, or the 2-4 select SW is off, and the detection SW (Shift diff. lock) is on, put in to H4L position. When switched from H4F to H4L, current flows from the 4WD fuse to TERMINAL 12 of the 4WD ECU to TERMINAL 26 to TERMINAL 2 of the 2-4 select motor to TERMINAL 3 to TERMINAL 13 of the 4WD ECU to TERMINAL 25 to GROUND, so the 2-4 select motor rotates at H4L position. When switched from H2 to H4L, current flows from the 4WD fuse to TERMINAL 12 of the 4WD ECU to TERMINAL 13 to TERMINAL 3 of the 2-4 select motor to TERMINAL 2 to TERMINAL 26 of the 4WD ECU to TERMINAL 25 to GROUND, so the 2-4 select motor rotates at H4L position.

#### (2) Shift limit control

When the vehicle speed is over 100 km/h, shift change to H4 or H4L mode can not be made. The vehicle speed signal is input to TERMINAL 3 of the 4WD ECU. At this time, the 4WD indicator light and the center diff. lock indicator light flashes, and the buzzer installed in the 4WD ECU goes on. This condition can be canceled by decelerating the vehicle speed to below 100 km/h, or by selecting H2 mode.

#### (3) Shift control

When the 2-4 select motor will not switch after approximately 3 seconds from shifting (When there are no changes to the signals to TERMINAL 8, TERMINAL 9 and TERMINAL 22 of the 4WD ECU), the 4WD indicator light and the center diff. lock indicator light flashes. The cruise control is canceled if in use. When the 2-4 select motor switch is completed, the indicator lights go off and the cruise control can be set again.

#### (4) ADD valve control

When switching between 2WD to 4WD, the VSV is controlled to free or lock the ADD. At this time, current flows from the 4WD fuse to TERMINAL 12 of the 4WD ECU to TERMINAL 23 to VSV (2WD, ADD) to GROUND, or flows from the 4WD fuse to TERMINAL 12 of the 4WD ECU to TERMINAL 10 to VSV (4WD, ADD) to GROUND, so the VSV (2WD, ADD) or VSV (4WD, ADD) is controlled.

### SERVICE HINTS

#### F7 4WD ECU

- 12-GROUND : Approx. 12 volts with ignition SW on
- 25-GROUND : Always continuity
- 3-GROUND : Pulse generation with vehicle moving

#### T3 2-4 SELECT SW

- 1-2 : Closed with 2-4 select SW on

#### P1 A/T INDICATOR LIGHT SW [PARK/NEUTRAL POSITION SW]

- 4-7 : Closed with A/T shift lever at **P** position
- 4-9 : Closed with A/T shift lever at **D** position

**○ : PARTS LOCATION**

Code	See Page	Code	See Page	Code	See Page
A10	26 (5VZ-FE)	D30	26 (5VZ-FE)	J7 A	31
A17	30	D31	26 (5VZ-FE)	J8 B	31
C18	26 (5VZ-FE)	D32	26 (5VZ-FE)	J9	31
C25 A	30	E12	31	P1	27 (5VZ-FE)
C26 C	30	F7	31	T1	27 (5VZ-FE)
C29 B	30	J1 A	27 (5VZ-FE)	T3	31
D4	26 (5VZ-FE)	J2 B	27 (5VZ-FE)	V4	27 (5VZ-FE)
D5	26 (5VZ-FE)	J3	31	V5	27 (5VZ-FE)
D29	30	J5	31		

**○ : JUNCTION BLOCK AND WIRE HARNESS CONNECTOR**

Code	See Page	Junction Block and Wire Harness (Connector Location)
1F	22	Cowl Wire and Driver Side J/B (Lower Finish Panel)
1J		
3E	24	Cowl Wire and Center J/B (Near the Steering Column Tube)

**□ : CONNECTOR JOINING WIRE HARNESS AND WIRE HARNESS**

Code	See Page	Joining Wire Harness and Wire Harness (Connector Location)
ED1	36 (5VZ-FE)	Engine Wire and Front Differential Wire (Near the Front Differential)
IG1	40	Engine Room Main Wire and Cowl Wire (Left Kick Panel)
II1	40	Engine Wire and Cowl Wire (on the Glove Box)
II2		
II3		

**▽ : GROUND POINTS**

Code	See Page	Ground Points Location
EB	36 (5VZ-FE)	Front Left Fender
IF	40	Cowl Side Panel RH

**○ : SPLICE POINTS**

Code	See Page	Wire Harness with Splice Points	Code	See Page	Wire Harness with Splice Points
I3	40	Engine Room Main Wire	I12	40	Cowl Wire
I5	40	Cowl Wire	I20		
I11	40	Engine Wire			

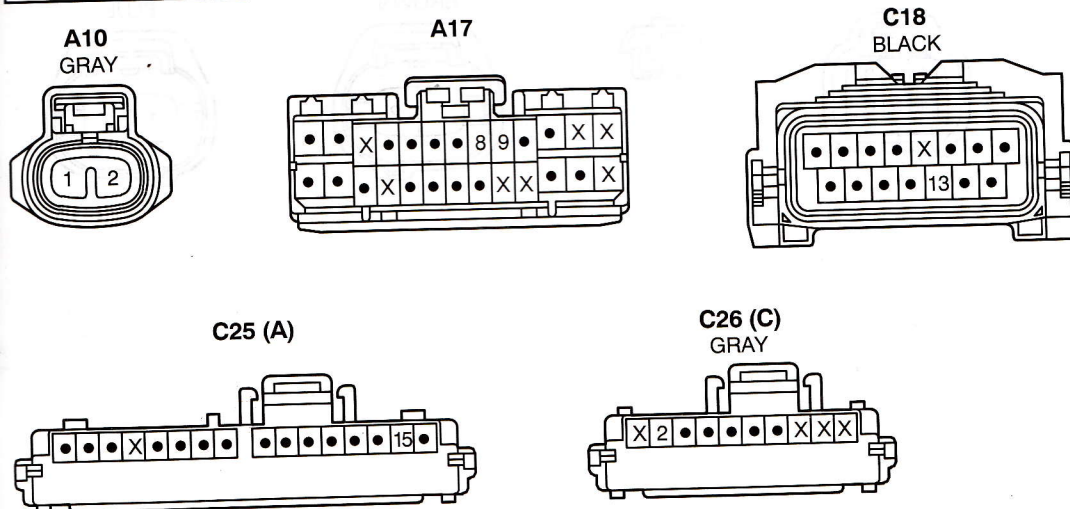

# 4WD (w/ 2-4 SELECT SW)

**C29 (B)**  
BROWN

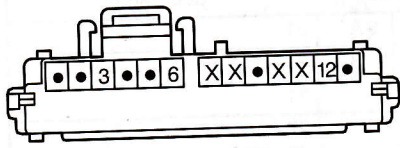

**D4**  
BLUE

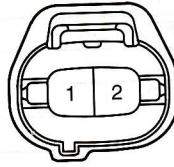

**D5**  
GRAY



**D29**

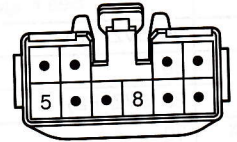

**D30**  
BLUE

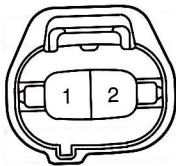

**D31**  
GRAY

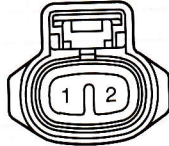

**D32**  
GRAY

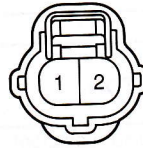

**E12**  
BLACK

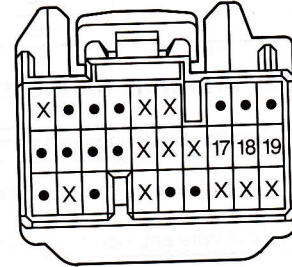

**F7**

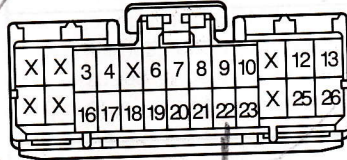

**J1 (A)**  
GRAY

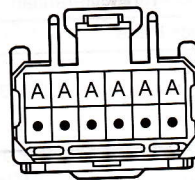

(Hint : See Page 7)

**J2 (B)**  
GRAY

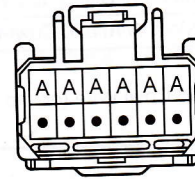

(Hint : See Page 7)

**J3**  
BLUE

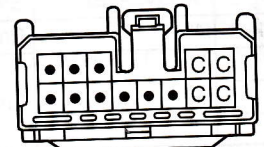

(Hint : See Page 7)

**J5**  
BLACK

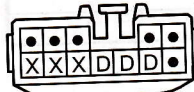

(Hint : See Page 7)

**J7 (A)**  
BLACK

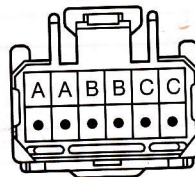

(Hint : See Page 7)

**J8 (B)**  
BLACK

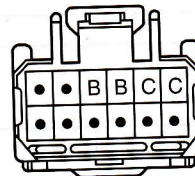

(Hint : See Page 7)

**J9**

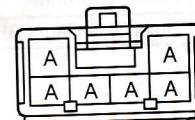

(Hint : See Page 7)

**P1**  
GRAY

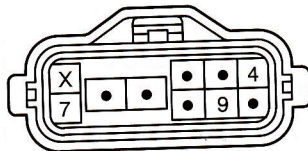

**T1**  
GRAY



**T3**



**V4**  
BROWN

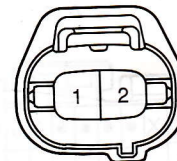

**V5**  
BLUE

