

ENGINE CONTROL (5VZ-FE)

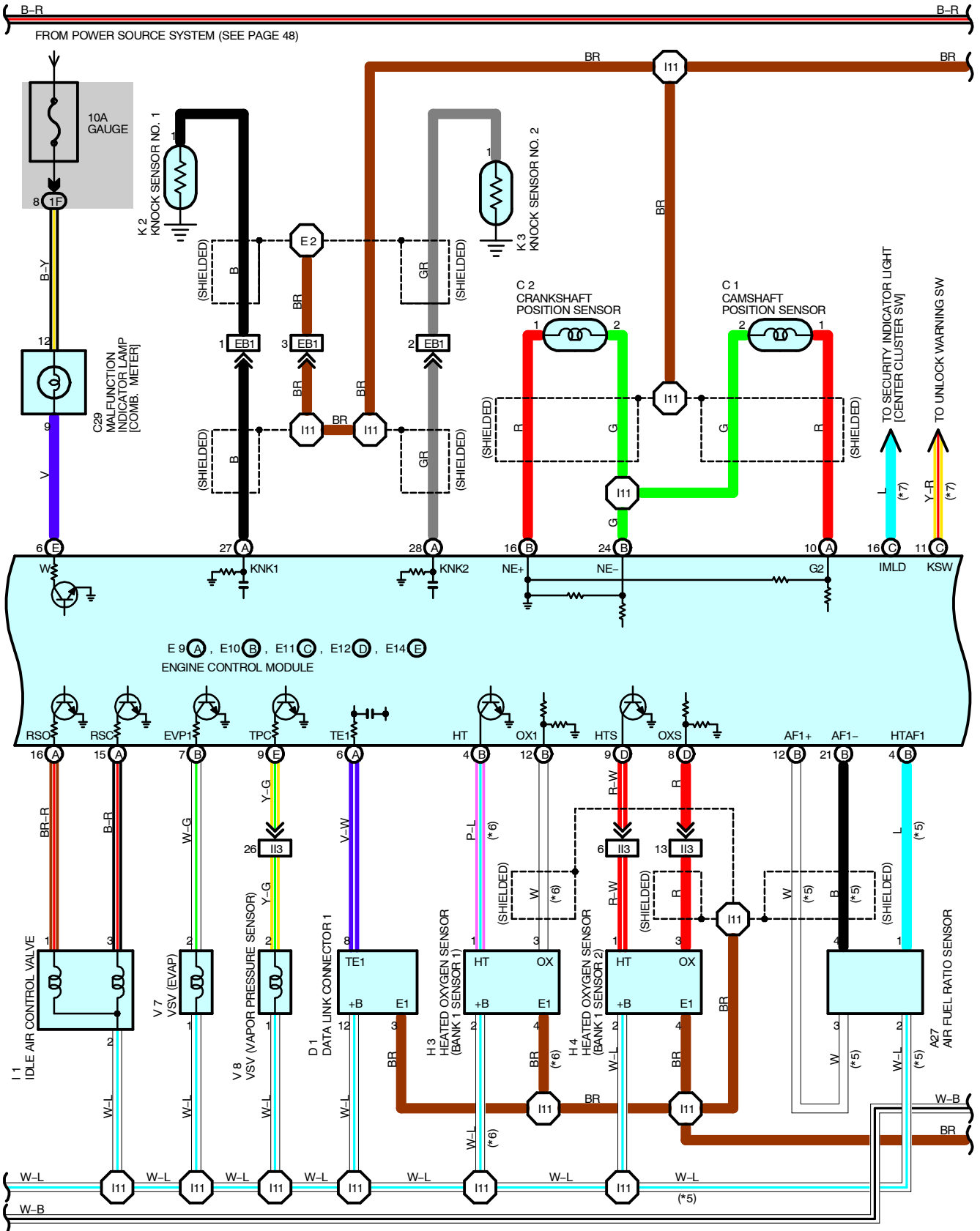

ENGINE CONTROL (5VZ-FE)

SYSTEM OUTLINE

The engine control system utilize a microcomputer and maintains overall control of the engine, transmission, etc. An outline of engine control is given here.

1. INPUT SIGNAL

(1) Engine coolant temp. signal system

The engine coolant temp. sensor detects the engine coolant temp. and has a built-in thermistor with a resistance which varies according to the engine coolant temp. The engine coolant temp. is input as a control signal to TERMINAL THW of the engine control module.

(2) Heated oxygen sensor signal system

The oxygen density in the exhaust emissions is detected and input as a control signal to TERMINAL OX1 or OXS of the engine control module. To maintain stable detection performance by the heated oxygen sensor, the heated oxygen sensors are warmed. The heater is also controlled by the engine control module (HT or HTS).

(3) RPM signal system

Camshaft position and crankshaft position are detected by the camshaft position sensor and crankshaft position sensor, camshaft position is input as a control signal to TERMINAL G2 of the engine control module, and engine RPM is input to TERMINAL NE+.

(4) Throttle signal system

The throttle position sensor detects the throttle valve opening angle, which is input as a control signal to TERMINAL VTA of the engine control module.

(5) Vehicle speed signal system

The vehicle speed sensor, detects the vehicle speed and input to ABS speed sensor of the ABS ECU, from ABS ECU to TERMINAL SP1 of the engine control module, via combination meter.

(6) A/C SW signal system

The operating voltage of the A/C magnetic clutch is detected and input as a control signal to TERMINAL AC1 of the engine control module.

(7) Battery signal system

Voltage is constantly applied to TERMINAL BATT of the engine control module. When the ignition SW is turned to on, voltage for engine control module operation is applied via the EFI relay to TERMINAL +B of the engine control module.

(8) Intake air volume signal system

Intake air volume is detected by the mass air flow meter and a signal is input into TERMINAL VG of the engine control module as a control signal.

(9) Stop light SW signal system

The stop light SW is used to detect whether or not the vehicle is braking and the information is input as a control signal to TERMINAL STP of the engine control module.

(10) Starter signal system

To confirm that the engine is cranking, the voltage applied to the starter motor during cranking is detected and is input as a control signal to TERMINAL STA of the engine control module.

(11) Engine knock signal system

Engine knocking is detected by the knock sensor no. 1 and no. 2 and the signals are input to TERMINALS KNK1 and KNK2 of the engine control module.

(12) 4WD signal system (4WD)

Whether or not the vehicle is operating in 4WD mode is determined, and a control signal is input to TERMINAL 4WD of the engine control module.

(13) Intake air temp. signal circuit

The intake air temp. sensor is installed in the mass air flow meter and detects the intake air temp., which is input as a control signal into TERMINAL THA of the engine control module.

(14) Air fuel ratio signal system (California)

The air fuel ratio is detected and input as a control signal into TERMINAL AF1+ of the engine control module.

2. CONTROL SYSTEM

*** SFI system**

The SFI system monitors the engine conditions through the signals each sensor inputs to the engine control module. Based on this data and the program memorized in the engine control module, the most appropriate fuel injection timing is detected and current is output to TERMINALS #10, #20, #30, #40, #50 AND #60 of the engine control module, causing the injectors to operate (to inject fuel). It is this system which, through the work of the engine control module, finely controls fuel injection in response to driving conditions.

*** ESA system**

The ESA system monitors the engine conditions using the signals input to the engine control module from each sensor. Based on this data and the program memorizes in the engine control module, the most appropriate ignition timing is decided and current is output to TERMINALS IGT1, IGT2 and IGT3 of the engine control module. This output controls the igniter to produce the most appropriate ignition timing for the driving conditions.

*** Heated oxygen sensor heater control system**

The heated oxygen sensor heater control system turns the heater to on when the intake air volume is low (Temp. of exhaust emissions is low). And warms up the heated oxygen sensors to improve detection performance of the sensors. The engine control module evaluates the signals from each sensor current is output to TERMINAL HT or HTS and controls the heater.

3. DIAGNOSIS SYSTEM

With the diagnosis system, when there is a malfunction in the ECU signal system, the malfunctioning system is recorded in the memory. The malfunctioning system can then be found by reading the display (Code) of the malfunction indicator lamp.

4. FAIL- SAFE SYSTEM

When a malfunction occurs in any system, if there is a possibility of engine being caused by continued control based on the signals from that system, the fail-safe system either controls the system by using data (Standard values) recorded in the engine control module memory or else stops the engine.

ENGINE CONTROL (5VZ-FE)

SERVICE HINTS

EFI RELAY [ENGINE ROOM R/B]

5-3 : Closed with ignition SW at **ON** or **ST** position

C6 CIRCUIT OPENING RELAY

5-3 : Closed with starter running or ignition SW at **ON** position

I6, I7, I8, I9, I10, I11 INJECTOR

1-2 : **13.4-14.2** Ω

T2 THROTTLE POSITION SENSOR

1-2 : **2.5-5** kΩ

E3 ENGINE COOLANT TEMP. SENSOR

1-2 : **10-20** kΩ (-20°C, -4°F)

4-7 kΩ (0°C, 32°F)

2-3 kΩ (20°C, 68°F)

0.9-1.3 kΩ (40°C, 104°F)

0.4-0.7 kΩ (60°C, 140°F)

0.2-0.4 kΩ (80°C, 176°F)

E9 (A), E10 (B), E14 (E) ENGINE CONTROL MODULE

Voltage at engine control module wiring connectors

+B-E1 : **9-14** volts (Ignition SW on)

BATT-E1 : **9-14** volts (Always)

VC-E2 : **4.5-5.5** volts (Ignition SW on)

VTA-E2 : Approx. **0.6** volts (Ignition SW on and throttle valve fully closed)

Approx. **4** volts (ignition SW on and throttle valve fully open)

STA-E1 : **6** volts or more (Ignition SW at **ST** position)

W-E1 : **9-14** volts (No trouble and engine running)

THW-E1 : **0.2-1.0** volts (Ignition SW on and coolant temp. **80°C, 176°F**)

SP1-E1 : Pulse generation with vehicle moving

STP-E1 : **7.5-14** volts (Stop light SW on)

IGT1, IGT2, IGT3-E1 : Pulse generation (Cranking or idling)

#10, #20, #30, #40, #50, #60-E1 : **9-14** volts (Ignition SW on)

RESISTANCE AT ECU WIRING CONNECTOR

(Disconnect wiring connector)

THW-E2 : **0.2-0.4** kΩ (Coolant temp. **80°C, 176°F**)

NE+-E2 : **140-180** Ω

○ : PARTS LOCATION

Code	See Page	Code	See Page	Code	See Page		
A12	A	30	H3	26 (5VZ-FE)	J6	31	
A27		26 (5VZ-FE)	H4	26 (5VZ-FE)	J7	A	31
A30	B	30	I1	27 (5VZ-FE)	J8	B	31
C1		26 (5VZ-FE)	I2	27 (5VZ-FE)	J9		31
C2		26 (5VZ-FE)	I3	27 (5VZ-FE)	J12		32
C6		30	I4	27 (5VZ-FE)	K2		27 (5VZ-FE)
C18		26 (5VZ-FE)	I5	27 (5VZ-FE)	K3		27 (5VZ-FE)
C29		30	I6	27 (5VZ-FE)	M1		27 (5VZ-FE)
D1		26 (5VZ-FE)	I7	27 (5VZ-FE)	P22		27 (5VZ-FE)
D7		30	I8	27 (5VZ-FE)	S4		31
E3		26 (5VZ-FE)	I9	27 (5VZ-FE)	T2		27 (5VZ-FE)
E9	A	31	I10	27 (5VZ-FE)	T6		31
E10	B	31	I11	27 (5VZ-FE)	V1		27 (5VZ-FE)
E11	C	31	I14	31	V7		27 (5VZ-FE)
E12	D	31	J1	A	27 (5VZ-FE)	V8	27 (5VZ-FE)
E14	E	31	J2	B	27 (5VZ-FE)		
F10		32	J4	31			

○ : RELAY BLOCKS

Code	See Page	Relay Blocks (Relay Block Location)
2	20	Engine Room R/B (Engine Compartment Left)

○ : JUNCTION BLOCK AND WIRE HARNESS CONNECTOR

Code	See Page	Junction Block and Wire Harness (Connector Location)
1F	22	Cowl Wire and Driver Side J/B (Lower Finish Panel)
1I	22	Engine Room Main Wire and Driver Side J/B (Lower Finish Panel)
1J	22	Cowl Wire and Driver Side J/B (Lower Finish Panel)
3C	24	Cowl Wire and Center J/B (Near the Steering Column Tube)
3E		

□ : CONNECTOR JOINING WIRE HARNESS AND WIRE HARNESS

Code	See Page	Joining Wire Harness and Wire Harness (Connector Location)
EB1	36 (5VZ-FE)	Sensor Wire and Engine Wire (Front Side of Cylinder Head Cover Right)
EC1	36 (5VZ-FE)	Engine Wire and Water Temp. Sensor Wire (Front Side of Cylinder Head Cover Right)
IE1	40	Cowl Wire and Floor No.2 Wire (Left Kick Panel)
IG1	40	Engine Room Main Wire and Cowl Wire (Left Kick Panel)
II3	40	Engine Wire and Cowl Wire (on the Glove Box)
IJ1	40	Cowl Wire and A/C Sub Wire (Near the A/C Unit)

▽ : GROUND POINTS

Code	See Page	Ground Points Location
EB	36 (5VZ-FE)	Front Left Fender
EC	36 (5VZ-FE)	Intake Manifold Left
IE	40	Cowl Side Panel LH
IF	40	Cowl Side Panel RH

○ : SPLICE POINTS

Code	See Page	Wire Harness with Splice Points	Code	See Page	Wire Harness with Splice Points
E2	36 (5VZ-FE)	Sensor Wire	I11	40	Engine Wire
I6	40	Cowl Wire	I21	40	Cowl Wire

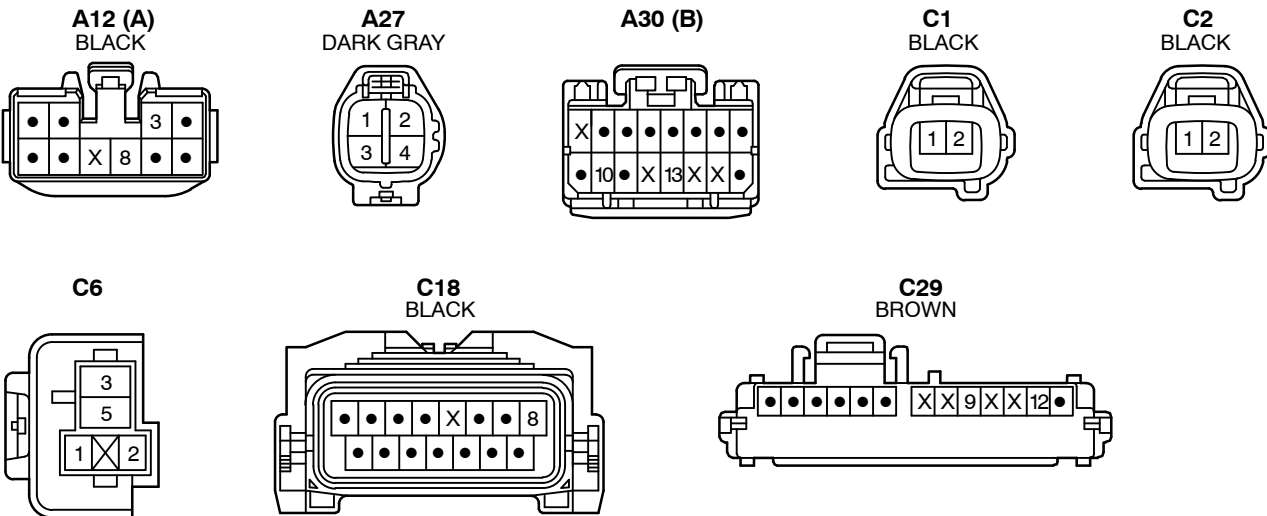

ENGINE CONTROL (5VZ-FE)

D1
BLACK

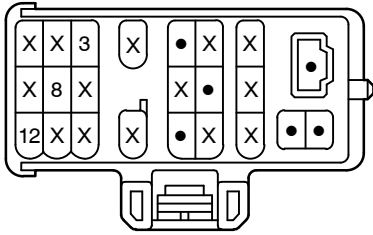

D7
BLACK

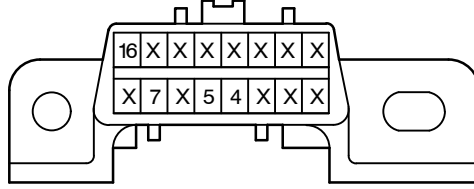

E3
DARK GRAY



E9 (A)

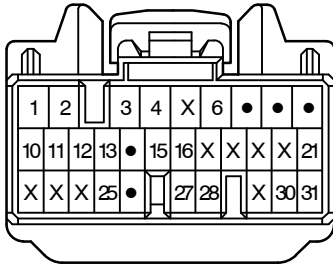

E10 (B)

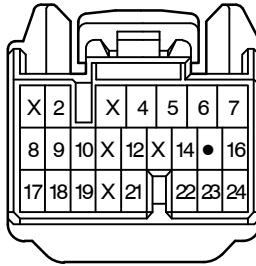

E11 (C)

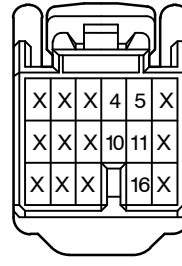

E12 (D)
BLACK

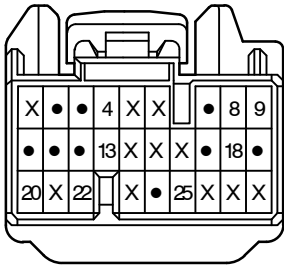

E14 (E)

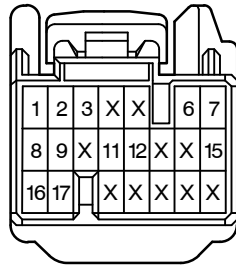

F10
DARK GRAY

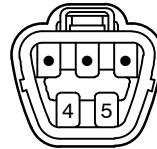

H3
DARK GRAY



H4
DARK GRAY



I1
GRAY



I2
BLACK

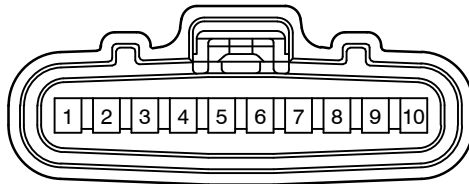

I3
BLACK

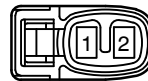

I4
BLACK

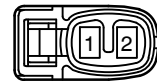

I5
BLACK

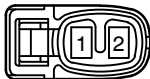

I6
BROWN



I7
BROWN



I8
BROWN



I9
BROWN



I10
BROWN



I11
BROWN



I14

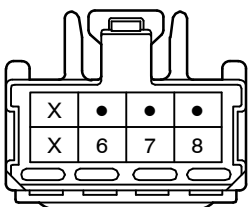

J1 (A)
GRAY

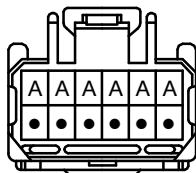

(Hint : See Page 7)

J2 (B)
GRAY

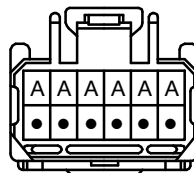

(Hint : See Page 7)

J4

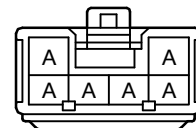

(Hint : See Page 7)

