

- Using a razor blade and gasket scraper, remove all the packing (FIPG) material from the gasket surfaces.
- Thoroughly clean all components to remove all the loose material.
- Clean both sealing surfaces with a non-residue solvent.

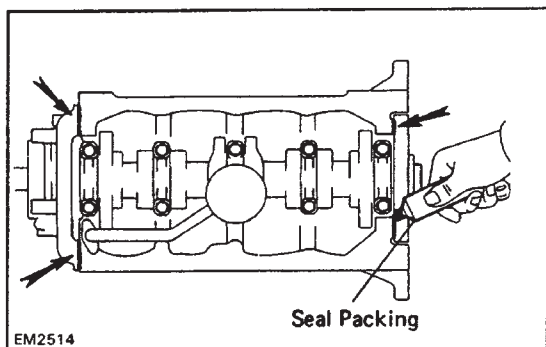

**NOTICE: Do not use a solvent which will affect the painted surfaces.**

(b) Apply seal packing to the joint part of the cylinder block and chain cover, cylinder block and rear oil seal retainer.

**Seal packing: Part No.08826-00080 or equivalent**

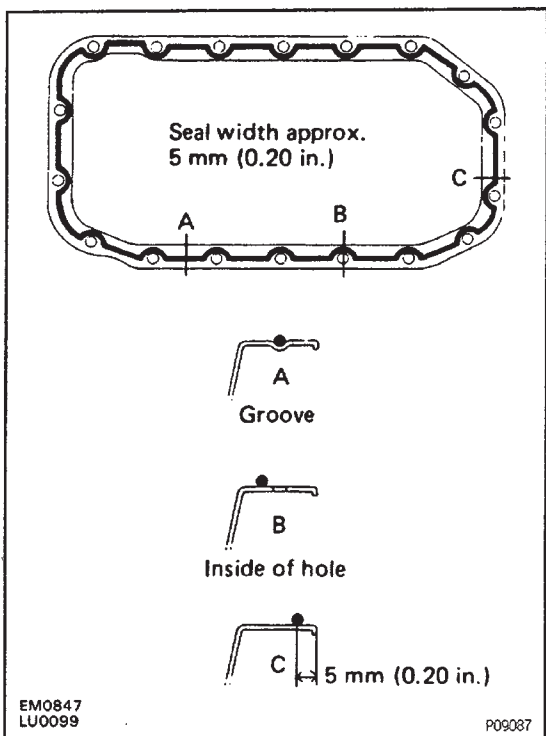

(c) Apply seal packing to the oil pan as shown in the illustration.

**Seal packing: Part No.08826-00080 or equivalent**

Install a nozzle that has been cut to a 5-mm (0.20 in.) opening.

HINT: Avoid applying an excess amount to the surface. Be especially careful near oil passages.

- If parts are not assembled within 5 minutes of applying the seal packing, the effectiveness of the seal packing is lost and the seal packing must be removed and reapplied.
- Immediately remove the nozzle from the tubs and reinstall the cap after using the seal packing.

(d) Install the oil pan over the studs on the block with the sixteen bolts and two nuts. Torque the bolts and nuts.

**Torque: 13N-m(130kgf-cm, 9ft-lbf)**

(e) Lower the engine and install the engine mounting bolts.

(f) Install the engine under cover.

## POST INSTALLATION

### 1. INSTALL RADIATOR

### 2. INSTALL CYLINDER HEAD

(See page [EG1-34](#))

### 3. (4WD) INSTALL FRONT DIFFERENTIAL

(See SA section)