



Toyota Motor Sales, U.S.A., Inc.
19001 South Western Avenue
P.O. Box 2991
Torrance, CA 90509-2991
(310) 618-4000
(310) 618-7800 Fax

TO: ALL TOYOTA DEALER PRINCIPALS,
SERVICE MANAGERS, PARTS MANAGERS

SUBJECT: **SPECIAL POLICY ADJUSTMENT FOR 1988 – EARLY 1990 TRUCK &
4RUNNER WITH 3VZ-E V6 ENGINES
AND
SPECIAL SERVICE CAMPAIGN (V06) FOR 1990 – EARLY 1995 TRUCK,
4RUNNER & T100 WITH 3VZ-E V6 ENGINES**

3VZ-E Head Gasket Special Policy Adjustment

In October 1996, Toyota announced a Special Policy Adjustment that provided extended warranty coverage for the head gaskets of certain 1988–1994 Toyota Compact Pickup Truck, 4Runner, and T100 equipped with the 3VZ-E V6 engine. This Special Policy Adjustment extended the warranty coverage for the head gaskets to 8 years or 100,000 miles (whichever occurred first) or 12 months from the date of the owner notification letter.

Commencing in Dec., 1997, Toyota will proceed with the Special Policy Adjustment Warranty Extension program by notifying the remaining owners of 1988, 1989 and early production (up to 12/89 production date) Toyota Compact Pick-up Truck and 4Runner equipped with 3VZ-E V6 engines who have not previously received any notification or have not received any head gasket repairs from a Toyota dealer since October 1, 1996.

Since introducing this Special Policy Adjustment, Toyota has identified that the head gasket failure condition is primarily limited to a particular production period of the involved vehicles. As a result, for a specific group of the vehicles previously involved in the Special Policy Adjustment, Toyota is now changing the handling procedure to a Special Service Campaign.

3VZ-E Head Gasket Special Service Campaign (V06)

With the introduction of the new Special Service Campaign(V06), owners of late production 1990, all 1991, 1992, 1993, and 1994 up to early production 1995 (1/90 to 10/94 production date) Toyota Compact Pick-up Truck, 4Runner and T100 equipped with 3VZ-E V6 engines who have not received any head gasket repairs from a Toyota dealer since October 1, 1996 will be notified to contact a Toyota dealer for head gaskets replacement.

Vehicle owners who have previously paid for head gasket replacement will be instructed to call the National Customer Relations Department at 1-800-404-7636 to obtain further directions.

3VZ-E SPA/SSC—V06

Page 2

The following information is provided to inform you and your staff of the Special Policy Adjustment/Special Service Campaign Program procedure and your degree of involvement:

Special Policy Adjustment/Special Service Campaign Program Details

	Special Policy Adjustment	Special Service Campaign
Which 3VZ-E V6 equipped vehicles are affected?	1988 through early 1990 Toyota Compact Pick-up Truck and 4Runner. (See VIN range listing for actual involved vehicles).	Late 1990 through early 1995 Toyota Compact Pick-up Truck, 4Runner and T100 vehicles. (See VIN range listing for actual involved vehicles).
Who will be notified?	Owners that have not been previously notified or received repairs since Oct. 1, 1996.	Owners who have not previously received repairs since Oct. 1, 1996.
What will Toyota do?	Owners of the involved vehicles under the Special Policy Adjustment Program will be provided a dated warranty extension document to keep with their vehicle owner's guide. If a head gasket fails within the 8 years or 100,000 miles extended warranty period, or within 12 months from the date of the owner notification letter, they can contact any Toyota dealer to have both head gaskets replaced at no cost to them.	Under the Special Service Campaign Program, the head gaskets will be replaced on all the affected vehicles regardless of leakage or not, and there will not be any age, mileage or time restrictions under the Special Service Campaign.
What will Toyota dealers do?	On the vehicles <u>WHERE THE HEAD GASKETS HAVE FAILED</u>, Toyota dealers will install new head gaskets at no cost to the owner. Other engine components, damaged as a result of a head gasket failure , will also be eligible for repair or replacement under this warranty.	Toyota dealers will install new head gaskets at no cost to the owner regardless of leakage or not.
Are all repairs at no cost to the customers?	Under both programs, the head gaskets and the related repairs will be covered by Toyota. However, while the engine is disassembled, it may also be advantageous for the customer to have other maintenance and repairs performed. Please note that these items are at customer expense as they are not related to the durability of the head gasket.	
When will owners be notified?	Mailing will commence in Dec, 1997 and continue until all involved vehicle owners are notified. The volume and frequency of mailings will depend on parts supply and dealer repair capacity.	

3VZ-E SPA/SSC—V06

Page 3

Please review this entire package with your Service and Parts staff to familiarize them with the proper step-by-step procedure and implement this Special Policy Adjustment/Special Service Campaign Program to ensure customer satisfaction.

Thank you for your cooperation.

TOYOTA MOTOR SALES, U.S.A., INC.
Customer Services Division

SPECIAL POLICY ADJUSTMENT

SPA Expired

SSC Still Active

3VZ-E HEAD GASKET SPA

Page 1

1. **Owner Notification Letters Mailing Date**

Commencing in December, 1997 (Copy attached)

2. **Identification of Involved Special Policy Adjustment Program Vehicles**

Vehicle Model	VDS	VIN Range
1988 – 1989 4Runner	VN66W VN62M VN62N	0000001 – 0040703
1988 Truck 4X4 Std Bed	VN63C VN63M	0000001 – 0040703
1988 Truck 4X4 Long Bed & Xtracab	VN64N VN67M VN67N	0000001 – 0011623
1989 – 1990 Truck 4X2 Long Bed & One Ton	VN82D VN82N	0000001 – 0003070 and 5000001 – 5003062
1989 – 1990 Cab Chassis Regular Wheelbase	VN82R VN82T	0000001 – 0003070 and 5000001 – 5003062
1989 – 1990 Truck 4X2 Xtracab	VN93D VN93G	0000001 – 0006118 and 5000001 – 5009265
1989 – 1990 Cab Chassis Long Wheelbase	VN94T	0000001 – 0014059
1989 – 1990 Truck 4X4 Std Bed	VN01D VN01G	0000001 – 0001355 and 2000001 – 2006626 and 6000001 – 6006342
1989 – 1990 Truck 4X4 Long Bed	VN02D	0000001 – 0000194 and 2000000 – 2001257 and 6000000 – 6002131
1989 – 1990 Truck 4X4 Xtracab	VN13D VN13G	0000001 – 0016346 and 5000001 – 5021512
1990 4Runner 4X2	VN29V	0000001 – 0002751
1990 4Runner 4X4	VN39J VN39W	0000001 – 0031089

SPA Expired
SSC Still Active

3. Technical Instructions and Guidelines for Special Policy Adjustment

- Refer to the applicable repair manuals for repair procedures and specifications.
- Replace both left and right head gaskets even if only one side is leaking.
- Inspect cylinder heads and blocks for warpage and erosion per attached instruction. Also see video tape previously released in February, 1997.
- If the cylinder head or block mating surface is warped or eroded beyond service specification, repair the heads and/or blocks by machining up to a combined maximum of 0.25 mm (0.010 in) from the cylinder head mating surfaces. If the warpage or erosion exceeds the maximum specification, the cylinder head or short block assembly must be replaced.

PLEASE NOTE: DSM inspection and authorization is required if the short block assembly is to be replaced. Refer to Policy No: 5.3 of the Warranty Policy and Procedures Manual.

- Additional parts and fluids that are required as a result of performing the head gasket replacement are also covered.

4. Parts Ordering

To avoid parts shortages, please observe the following guidelines for conservative parts ordering:

- **Stock only basic gaskets and non-reusable parts.**
- **Order major parts only as required to repair failed vehicles.**
- **Replenishment orders of gaskets and non-reusable parts should be based on a “sell one, buy one” basis.**
- **Parts ordering will be reviewed based on dealer’s submitted claims.**

The cylinder head gasket kit as well as related necessary parts can be ordered from your facing Parts Distribution Center.

PART NUMBER	DESCRIPTION
04007-02135	Cylinder Head Gasket Kit

SPA Expired
SSC Still Active

5. Operation Flow Chart for Special Policy Adjustment

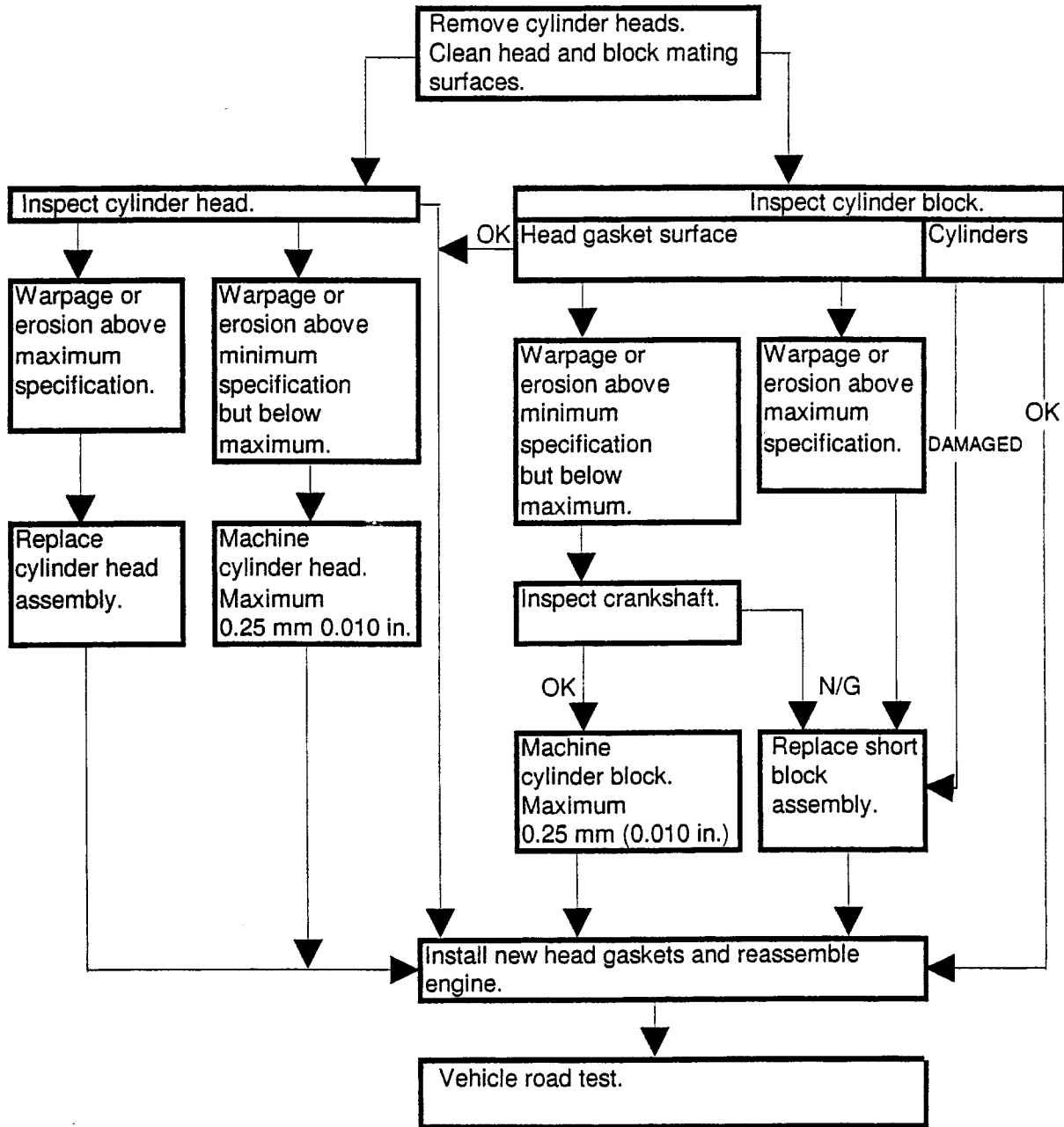

SPA Expired
SSC Still Active

3VZ-E Head Gasket SPA

Page 4

6. Reimbursement Procedures

Submit warranty claims following the regular procedures described in the Toyota Warranty Policy & Procedures Manual. The following operation codes are applicable for:

- **Head gasket replacement within 8 years or 100,000 miles Special Policy Adjustment, or**
- **Head gasket replacement within 12 months after customer received dated Warranty Extension document**

Please refer to the following VDS vs. Japan Model Code reference table to determine the applicable flat rate time.

VDS	Model	VDS	Model
VN62N VN62M VN63C VN63M VN66W	VZN61	VN64N VN67M VN67N	VZN66
VN82D VN82N VN82R VN82T	VZN85	VN93D VN93G	VZN90
VN94T	VZN95	VN01D VN01G	VZN100
VN02D	VZN105	VN13D VN13G	VZN110
VN29V	VZN120	VN39J VN39W	VZN130

SPA Expired
SSC Still Active

SPA-3VZ-E Operation Code		FLAT RATE HOURS		
		VZN61 VZN66	VZN85 VZN90 VZN95 VZN120	VZN100 VZN105 VZN110 VZN130
1	110051 R&R HEAD GASKET			
	Varied Work Code N	8.5	6.6	6.6
	Comb Code A=Opposite side	-	2.0	2.0
	Comb Code Z =Opposite side	2.0	-	-
	Comb Code L=A/C	-	0.4	0.4
	Comb Code Z=Extra diagnostic time required for SPA procedures	-	2.0	2.0
2	110011 R&R CYLINDER HEAD			
	Varied Work Code N	14.3	10.4	10.4
	Comb Code A=Opposite cylinder head	-	4.0	4.0
	Comb Code Z=Opposite cylinder head	5.8	-	-
	Comb Code Z=Opposite head gasket	2.0	2.0	2.0
	Comb Code L=A/C	-	0.4	0.4
	Comb Code Z=Extra diagnostic time required for SPA procedures	-	5.8	5.8
3	111011 R&R CYLINDER BLOCK			
	Varied Work Code N	18.1	16.3	18.2
	Comb Code C=A/C	0.4	-	-
	Comb Code K=A/C	-	0.4	0.4
	Comb Code Z=Replace one head	2.0	2.0	2.0
	Comb Code Z=Replace both heads	4.0	4.0	4.0
4	120101 R&R SHORT BLOCK			
	Varied Work Code N	16.3	14.5	16.4
	Comb Code C=A/C	0.4	-	-
	Comb Code K=A/C	-	0.4	0.4
	Comb Code Z=Replace one head	2.0	-	-
	Comb Code C=Replace one head	-	2.0	2.0
	Comb Code Z=Replace both heads	4.0	-	-
	Comb Code CC=Replace both heads	-	4.0	4.0
5	EN7001 RESURFACE BLOCK	22.0	22.0	22.0

3VZ-E Head Gasket SPA

Page 6

Claim Submission:

Use Claim Type = "RG"

DSM authorization is required if the cylinder or short block is replaced.

T1 = 64 (Leaks)

T2 = 13 (Deformed –bent, twisted, warped, shrunk, wrinkled)

OPN = 11115-XXXXX

Enter actual cost in sublet column using the following sublet types:

Rental	= "ZZ"
Fluids	= "OF"
Machining	= "MC"
Towing	= "TW"

Enter CCR describing actual repair performed.

Rental Allowance:

Rentals for the SPA should be submitted on the repair claim using sublet type "ZZ." The rental guideline is a maximum 3 days at \$30.00 per day. If the rental is required for more than three days, or costs more than \$30.00 per day then DSM authorization is required on the claim. The rental should not be submitted on a separate claim.

SPA Expired
SSC Still Active

SAMPLE

1988 to Early 1990 Toyota Truck and 4Runner V6 Head Gasket Special Policy Adjustment Notice

Dear Toyota Owner:

Thank you very much for your patronage of Toyota. We are dedicated to providing vehicles of outstanding quality and value. As part of our constant effort to provide the best in customer satisfaction, we are introducing a Special Policy Adjustment for your vehicle.

What is the Special Policy Adjustment?

This Special Policy Adjustment is an extension to the vehicle warranty coverage for the engine cylinder head gaskets of Toyota Compact Pick-up Truck and 4Runner vehicles. The subject vehicles are equipped with the V6 engine and were produced from June 1987 through December 1989 (1988, 1989 and certain early production 1990 model year vehicles).

The head gasket warranty extension is for a period of 8 years or 100,000 miles (whichever comes first) from the date of first use. In addition, Toyota will assist owners who may have already exceeded the 8 years or 100,000 miles by making this repair available for a period of 12 months from the date of this letter. **Since this is not a recall, we recommend that you contact a Toyota dealer for this condition only if you experience symptoms of head gasket failure.**

Some of the symptoms that may indicate a head gasket problem are loss of engine coolant, unusually rough idling, continuous discharge of white exhaust smoke, or diminished engine performance.

What should you do?

Please detach the enclosed Special Policy Adjustment warranty extension card and insert it into the Owner's Guide for your vehicle. In the event that you experience a cylinder head gasket failure, contact any Toyota dealer to schedule an appointment for the free replacement of the head gaskets. Should other components be damaged as a result of the head gasket failure, they will also be eligible for repair or replacement under this Special Policy Adjustment warranty extension.

As head gasket replacement takes several hours to complete, it is important that you first call a Toyota dealer to make an appointment before bringing in your vehicle.

During the replacement of the head gaskets, some related parts may also be replaced as part of the repair at no cost to you if the condition was caused by the failure of the original head gasket.

While the engine is disassembled, it may also be advantageous for you to have other maintenance and repairs performed. Please refer to your owner's manual for the recommended maintenance schedule and list of items that are due for replacement based on the mileage and months of your vehicle. It may also be to your benefit to service or replace other items such as the timing belt, radiator, thermostat, hoses, water pump and valves during the gasket replacement. Please note that these items are at customer expense as they are not related to the durability of the head gasket.

If you have previously paid for replacement of the cylinder head gaskets, please call 1-800-404-7636 or mail your receipts to Toyota Motor Sales, USA, Inc., Mailstop G5000 for further assistance.

If you have other questions?

Please contact any Toyota dealer or call the Toyota Motor Sales, USA, Inc., Customer Assistance Center at 1-800-331-4331.

We have sent this notice in the interest of your continued satisfaction with our products, and we sincerely regret any inconvenience this condition may have caused you.

Sincerely,
TOYOTA MOTOR SALES, U.S.A., INC.
CORPORATE PRODUCT TECHNICAL

SPA Expired

SSC Still Active

SAMPLE

**SPECIAL POLICY ADJUSTMENT WARRANTY EXTENSION
1988 - EARLY 1990 TRUCK and 4RUNNER V6 ENGINE CYLINDER HEAD GASKETS**

APPLICABLE TO: 1990 TRUCK VIN: JT4VNXXXXXXXXXXXX.

The warranty coverage for the cylinder head gaskets of this vehicle will be for a period of 8 years or 100,000 miles (whichever occurs first) from the date of first use. Other engine components, damaged as a result of a head gasket failure, will also be eligible for repair or replacement under this warranty extension.

In addition, for vehicles which may have already exceeded the 8 years or 100,000 miles, this Special Policy Adjustment will also apply for a period of 12 months from the date of this letter.

KEEP THIS DOCUMENT WITH YOUR OWNER'S GUIDE. PRESENT IT TO ANY TOYOTA DEALER IF YOU EXPERIENCE A CYLINDER HEAD GASKET FAILURE.

**SPA Expired
SSC Still Active**

SPECIAL SERVICE CAMPAIGN

V06

3VZ-E Head Gasket SSC—V06

Page 1

1. Owner Notification Letters Mailing Date

Commencing in December, 1997 (copy attached)

2. Identification of Involved Special Service Campaign Program Vehicles

Vehicle Model	VDS	VIN Range
1990 – 1992 Truck 4X2 Long Bed & One Ton	VN82D VN82N	0003071 – 0004067 and 5003063 – 5005247
1990 – 1993 Cab Chassis Regular Wheelbase	VN82R VN82T	0003071 – 0004067 and 5003063 – 5005247
1990 – 1995 Truck 4X2 Xtracab	VN93D VN93G	5009266 – 5044036
1990 – 1993 Cab Chassis Long Wheelbase	VN94T	0014060 – 0032901
1990 – 1995 Truck 4X4 Std Bed	VN01D VN01G	0001356 – 0006877 and 2006627 – 2015028 and Z000001 – Z311415
1990 – 1992 Truck 4X4 Long Bed	VN02D	2001258 – 2002582
1990 – 1995 Truck 4X4 Xtracab	VN13D VN13G	5021513 – 5151019 and Z000001 – Z311529
1990 – 1995 4Runner 4X2	VN29V	0002752 – 0043478 and 9000000 – 9000904
1990 – 1995 4Runner 4X4	VN39J VN39W	0031090 – 0180701 and 8000000 – 8076027
1993 – 1995 T100 4X2	VD10A VD10B VD10C	0000001 – 0023886
1993 – 1995 T100 4X4	VD20A VD20C	0000001 – 0015886

3. Technical Instructions and Guidelines

- Refer to the applicable repair manuals for repair procedures and specifications.
- If there are signs of head gasket leakage, inspect cylinder heads and blocks for warpage and erosion per attached instruction. Also refer to video previously released in February, 1997.
- If the cylinder head or block mating surface is warped or eroded beyond service specification, repair the heads and/or blocks by machining up to a combined maximum of 0.25 mm (0.010 in) from the cylinder head mating surfaces. If the warpage or erosion exceeds the maximum specification, the cylinder head or short block assembly must be replaced.

PLEASE NOTE: DSM inspection and authorization is required if the short block assembly is to be replaced. Refer to Policy No: 5.3 of the Warranty Policy and Procedures Manual.

- Additional parts and fluids that are required as a result of performing the head gasket replacement are also covered.

4. Operation Flow Chart for Special Service Campaign

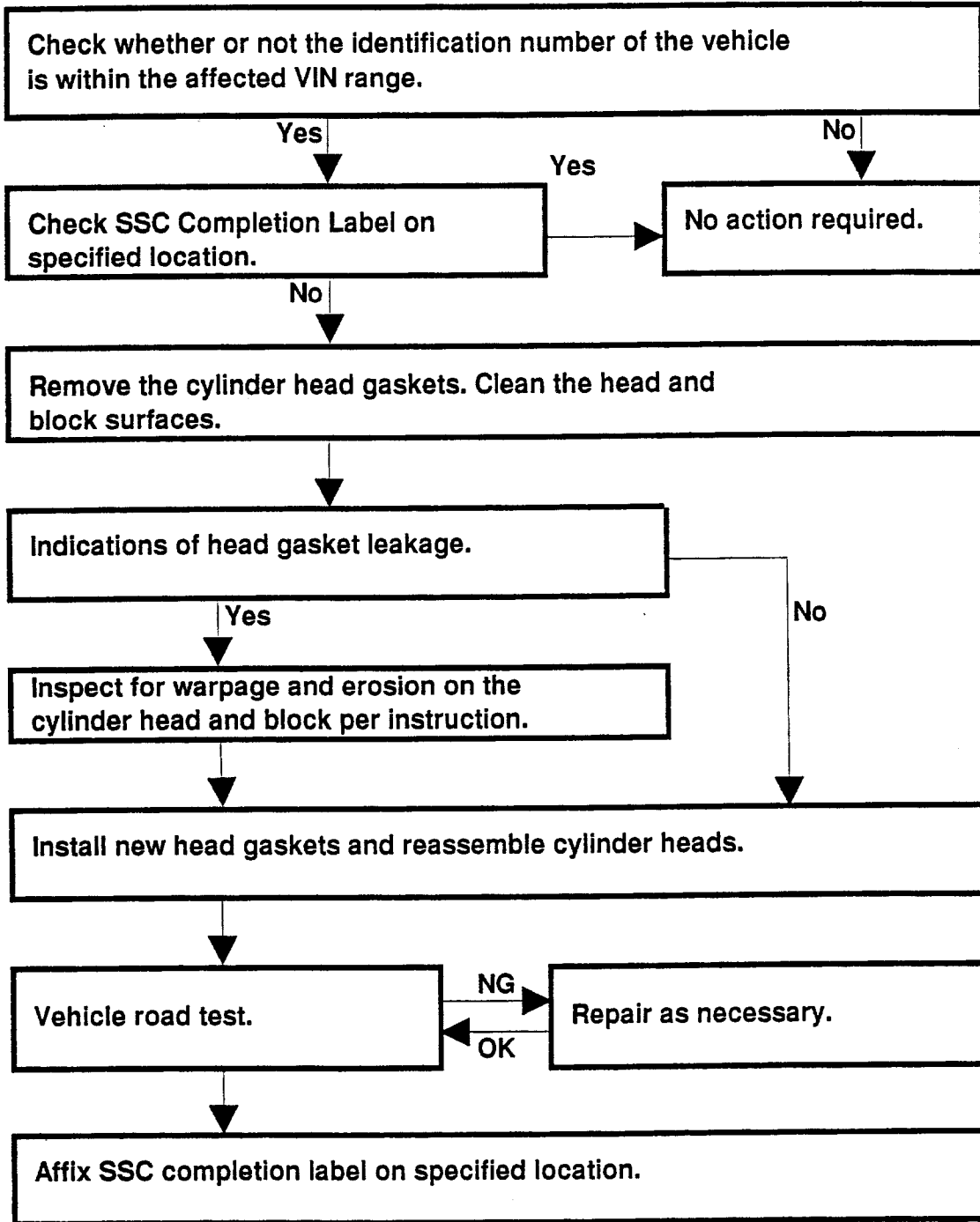

5. Parts Ordering

The supply of parts for this Special Service Campaign is extremely critical. To avoid parts shortage please observe the following guidelines for conservative parts ordering:

- A specific PMA dealer/owner list for each individual mailing will be provided to each dealer before any owner notifications are launched. Dealer’s parts order should not exceed 10% of the involved vehicles on the list.
- Replenishment orders of gaskets and non-reusable parts should be based on a “sell one, buy one” basis.
- Parts ordering will be reviewed based on dealer’s submitted claims.

The cylinder head gasket kit as well as related necessary parts can be ordered from your facing Parts Distribution Center.

PART NUMBER	DESCRIPTION
04007-02135	Cylinder Head Gasket Kit

6. Reimbursement Procedures

Submit warranty claims following the regular procedures described in the Toyota Warranty Policy & Procedures Manual. The following operation codes are applicable for: **Head gasket replacement under Special Service Campaign.**

Please refer to the following VDS vs. Japan Model Code reference table to determine the applicable flat rate time.

VDS	Model	VDS	Model
VN82D VN82N VN82R VN82T	VZN85	VN93D VN93G	VZN90
VN94T	VZN95	VN01D VN01G	VZN100
VN02D	VZN105	VN13D VN13G	VZN110
VN29V	VZN120	VN39J VN39W	VZN130
VD10A VD10B VD10C	VCK10	VD20A VD20C	VCK20

3VZ-E Head Gasket SSC—V06

Page 5

		FLAT RATE HOURS	
		VZN85 VZN90 VZN95 VZN120 VCK10	VZN100 VZN105 VZN110 VZN130 VCK20
SSC V06 Operation Code			
1	110051 R&R HEAD GASKET		
	Varied Work Code N	6.6	6.6
	Comb Code A=Opposite side	2.0	2.0
	Comb Code L=A/C	0.4	0.4
	Comb Code Z=Extra diagnostic time required for SSC procedures	2.0	2.0
2	110011 R&R CYLINDER HEAD		
	Varied Work Code N	10.4	10.4
	Comb Code A=Opposite cylinder head	4.0	4.0
	Comb Code Z=Opposite head gasket	2.0	2.0
	Comb Code L=A/C	0.4	0.4
	Comb Code Z=Extra diagnostic time required for SSC procedures	5.8	5.8
3	111011 R&R CYLINDER BLOCK		
	Varied Work Code N	16.3	18.2
	Comb Code K=A/C	0.4	0.4
	Comb Code Z=Replace one head	2.0	2.0
	Comb Code Z=Replace both heads	4.0	4.0
4	120101 R&R SHORT BLOCK		
	Varied Work Code N	14.5	16.4
	Comb Code K=A/C	0.4	0.4
	Comb Code C=Replace one head	2.0	2.0
	Comb Code CC=Replace both heads	4.0	4.0
5	EN7001 RESURFACE BLOCK	22.0	22.0

Claim Submission:

Use Claim Type = "RG."

DSM authorization is required if the cylinder head or short block is replaced.

T1 = 64 (Leaks)

T2 = 13 (Deformed –bent, twisted, warped, shrunk, wrinkled)

OPN = 11115-XXXXX

Claim type "SC" cannot be used for this SSC.

Enter actual cost in sublet column using the following sublet types:

Rental	= "ZZ"	Machining	= "MC"
Fluids	= "OF"	Towing	= "TW"

3VZ-E Head Gasket SSC—V06

Page 6

Enter CCR describing actual repair performed.

Rental Allowance:

Rentals for the SSC should be submitted on the repair claim using sublet type "ZZ." The rental guideline is a maximum 3 days at \$30.00 per day. If the rental is required for more than three days, or costs more than \$30.00 per day then DSM authorization is required on the claim. The rental should not be submitted on a separate claim.

7. SSC Completion Label Installation

(a) After completing repair and before returning vehicle to the owner, the SSC completion label that is enclosed in the owner's notification must be affixed to the left front door hinge post near the check strap.

(b) The label is to be filled out as follows:

Write in SSC V06
Write in date of repair
Write in your Dealer Code

The diagram shows a rectangular label form with a border. At the top, there are two small rectangular boxes: the left one is labeled "SSC" and the right one is labeled "Date". Below these boxes, the text "TOYOTA MOTOR SALES, U.S.A., INC." is printed. Underneath that, there is a larger rectangular box labeled "DEALER CODE NO.". In the bottom right corner of the label, the part number "00410-01917" is printed.

(c) Additional SSC completion labels, in sheets of 50 (P/N 00410-01917), may be ordered through the non-parts system on a 1450 order form or through the TDN system.

SAMPLE

Late 1990 to Early 1995 Toyota Truck, 4Runner and T100 V6 Head Gasket Special Service Campaign Notice

Dear Toyota Owner:

Thank you very much for your patronage of Toyota. We are dedicated to providing vehicles of outstanding quality and value. As part of our constant effort to provide the best in customer satisfaction, we are introducing a Special Service Campaign for your vehicle.

What is the problem?

The engine cylinder head gaskets of Toyota Compact Pick-up Truck, 4Runner, and T100 vehicles may leak leading to symptoms of loss of engine coolant, unusually rough idling, continuous discharge of white exhaust smoke, or diminished engine performance. The subject vehicles are equipped with the V6 engine and were produced from January 1990 through September 1994 (some 1990, all 1991, 1992, 1993, 1994 and early production 1995 model year vehicles).

What will Toyota do?

Any Toyota dealer will replace the cylinder head gaskets with improved gaskets at no cost to you.

As head gasket replacement takes several hours to complete, it is important that you first call a Toyota dealer to make an appointment before bringing in your vehicle.

During the replacement of the head gaskets, some related parts may also be replaced as part of the repair at no cost to you if the condition was caused by the failure of the original head gasket.

While the engine is disassembled, it may also be advantageous for you to have other maintenance and repairs performed. Please refer to your owner's manual for the recommended maintenance schedule and list of items that are due for replacement based on the mileage and months of your vehicle. It may also be to your benefit to service or replace other items such as the timing belt, radiator, thermostat, hoses, water pump and valves during the gasket replacement. Please note that these items are at customer expense as they are not related to the durability of the head gasket.

What should you do?

Contact any Toyota dealer as soon as possible to schedule an appointment for the free replacement of the head gaskets.

NOTE: If you have already had the head gaskets on your vehicle replaced at a Toyota dealer after October 1, 1996, they do not need to be replaced again.

Please present this notice to the dealer when you bring the vehicle in for your service appointment.

If you have previously paid for replacement of the cylinder head gaskets, please call 1-800-404-7636 or mail your receipts to Toyota Motor Sales, USA, Inc., Mailstop G5000 for further assistance.

If you have other questions?

Please contact any Toyota dealer or call the Toyota Motor Sales, USA, Inc., Customer Assistance Center at 1-800-331-4331.

We have sent this notice in the interest of your continued satisfaction with our products, and we sincerely regret any inconvenience this condition may have caused you.

Sincerely,

TOYOTA MOTOR SALES, U.S.A., INC.
CORPORATE PRODUCT TECHNICAL

TECHNICAL INSTRUCTIONS
FOR
CYLINDER HEAD AND BLOCK INSPECTION

3VZ-E Cylinder Head/Block Inspection

Page 1

Please use the attached technical instructions to inspect the cylinder heads and blocks of vehicles for warpage and erosion.

3VZ-E CYLINDER BLOCK AND HEAD SURFACE MACHINING

When replacing cylinder head gaskets on the 3VZ-E engine, careful inspection of the cylinder head and block mating surfaces is necessary to ensure a complete and durable repair. If cylinder head or block mating surfaces are warped or eroded, they may be reconditioned using the following guidelines.

CYLINDER HEAD INSPECTION

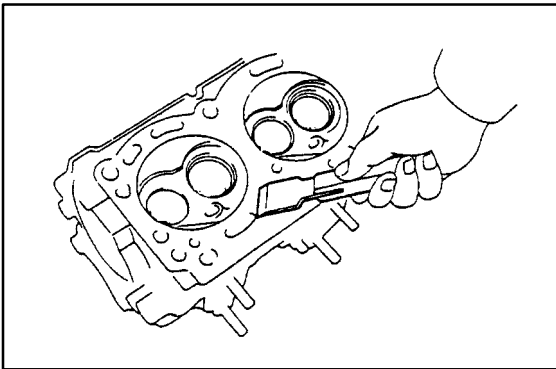

1. CLEAN CYLINDER HEAD

- (a). Using a gasket scraper, remove all the gasket material from the cylinder block contact surface.

NOTE: Be careful not to scratch the cylinder block contact surface.

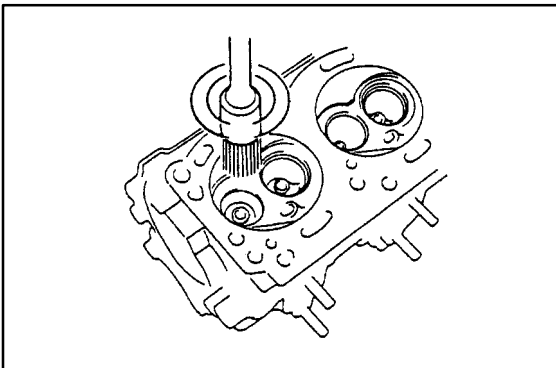

- (b). Using a wire brush, remove all the carbon from the combustion chambers.

NOTE: Be careful not to scratch the cylinder block contact surface.

- (c). Using a sanding block with 180 grit paper, thoroughly clean the cylinder block contact surface.

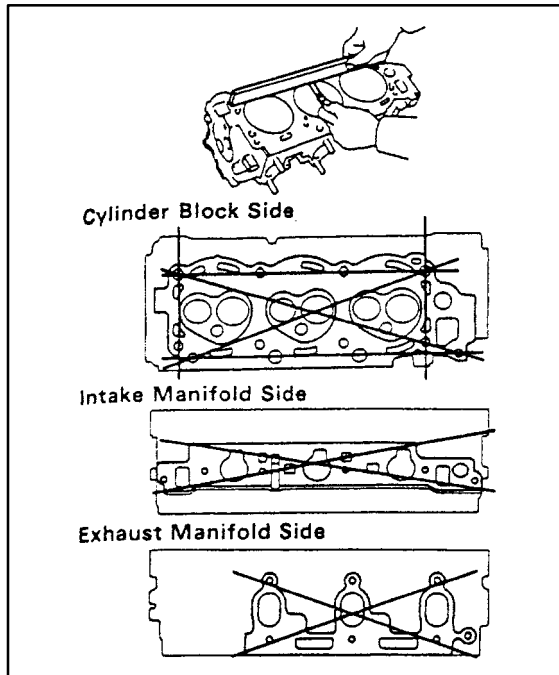

2. INSPECT CYLINDER HEAD FOR FLATNESS.

- (a). Using a precision straight edge and feeler gauge, measure the surfaces contacting the cylinder block and the manifolds for warpage.

CYLINDER HEAD MEASUREMENT		
Less than 0.10 mm (0.0039 in)	More than 0.10 mm (0.0039 in) but less than 0.25 mm (0.010 in)	More than 0.25 mm (0.010 in)
Cylinder head may be reused without machining	*Cylinder head may be machined to a maximum of 0.25 mm (0.010 in)	Cylinder head must be replaced

NOTE: WHEN MACHINING CYLINDER HEAD AND BLOCK THE COMBINED AMOUNT OF MATERIAL REMOVED MUST NOT EXCEED 0.25 mm (0.010 in).

3. MEASURE CYLINDER BLOCK CONTACT SURFACES FOR DEPTH OF EROSION.

- (a). Using a dial indicator, measure the depth of erosion of the surfaces contacting the cylinder head gasket.

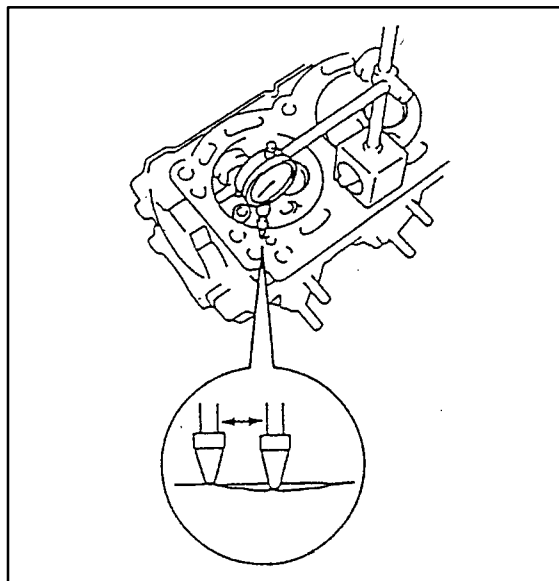

4. INSPECT VALVES AND VALVE SEATS.

- (a). With the cylinder head inverted and the spark plugs installed, fill the combustion chambers with solvent to determine if any of the valves or valve seats have been damaged by the entry of coolant into the cylinder.

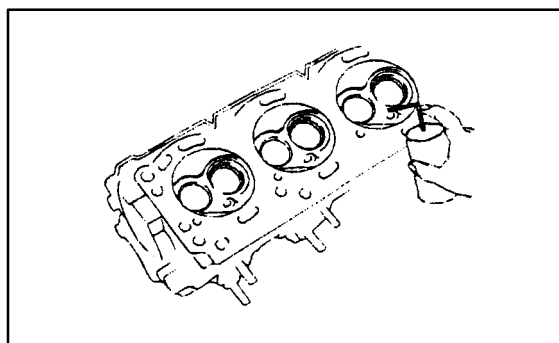

3VZ-E Cylinder Head/Block Inspection

Page 3

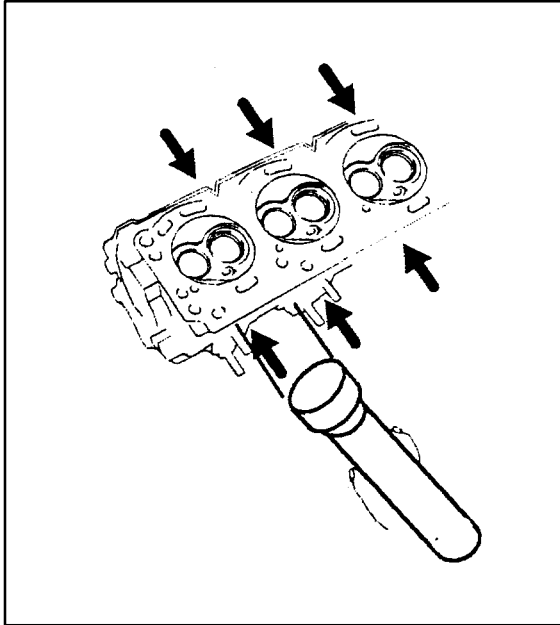

- (b) Examine the intake and exhaust ports for signs of the solvent leaking past the valve seats, paying particular attention to cylinders number one and number six. If any solvent leakage is detected those valves must be removed for further inspection and repair as necessary.

CYLINDER BLOCK INSPECTION

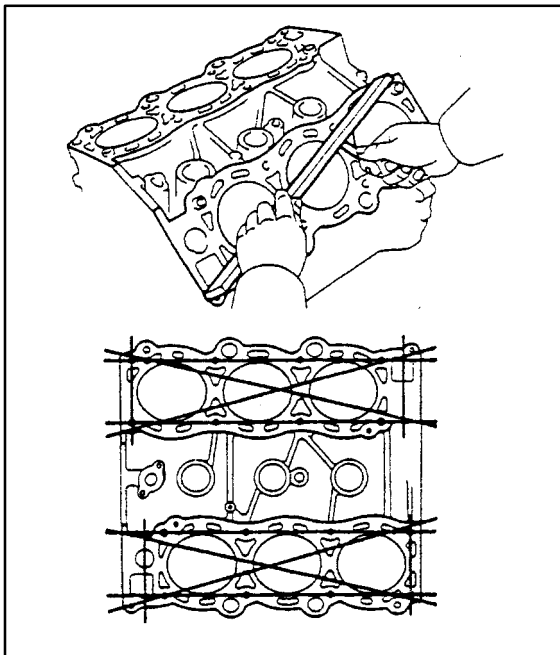
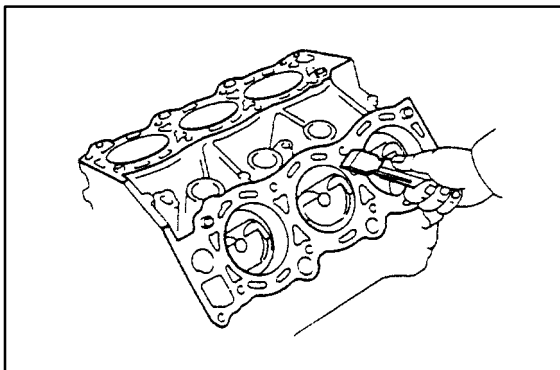
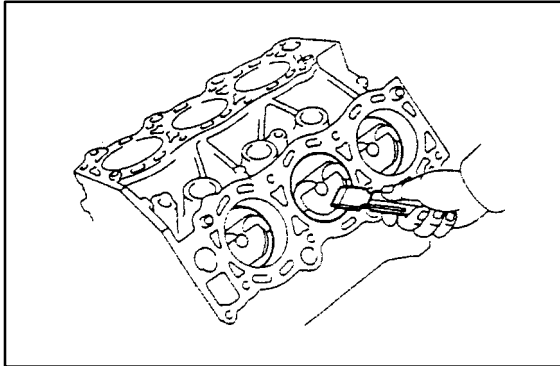

1. CLEAN TOP SURFACES OF PISTONS AND CYLINDER BLOCK

- (a). Turn the crankshaft, and bring each piston to top dead center (TDC). Using a gasket scraper, remove all the carbon from the piston top surface.
- (b). Using a gasket scraper, remove all the gasket material from the top surface of the cylinder block.
- (c). Using compressed air, blow carbon and oil from the cylinders and bolt holes.

NOTE: Protect your eyes when using compressed air.

- (d). Using a sanding block with 180 grit paper, thoroughly clean the top surface of the cylinder block.

2. MEASURE TOP SURFACE OF CYLINDER BLOCK FOR FLATNESS

- (a). Using a precision straight edge and feeler gauge, measure the surfaces contacting the cylinder head gasket for warpage.

BLOCK MEASUREMENT		
Less than 0.05 mm (0.002 in)	More than 0.05 mm (0.002 in) but less than 0.25 mm (0.010 in)	More than 0.25 mm (0.010 in)
Block may be reused without machining	*Block may be machined to a maximum of 0.25 mm (0.010 in)	Replace short block assembly

***NOTE: WHEN MACHINING CYLINDER HEAD AND BLOCK THE COMBINED AMOUNT OF MATERIAL REMOVED MUST NOT EXCEED 0.25 mm (0.010 in).**

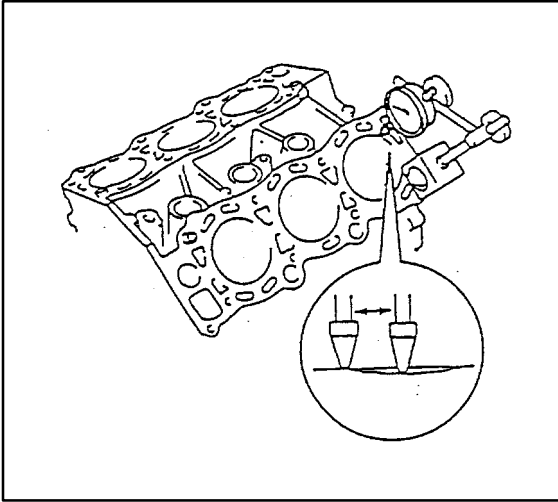

3. MEASURE TOP SURFACE OF CYLINDER BLOCK FOR EROSION.

- (a). Using a dial indicator, measure the depth of erosion of the surfaces contacting the cylinder head gasket.

CYLINDER WALL INSPECTION

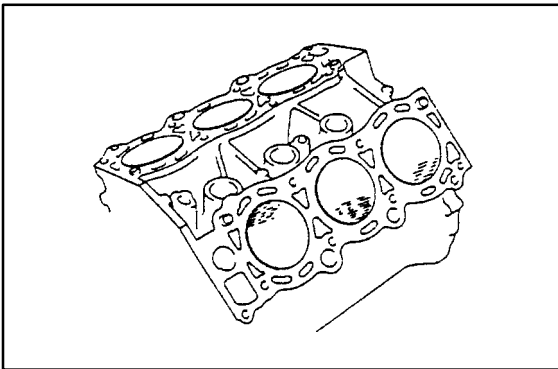

1. INSPECT CYLINDERS FOR VERTICAL SCRATCHES

- (a). Visually check the cylinders for vertical scratches. If deep scratches are present, replace the short block assembly.

PROCEDURE FOR INSPECTION OF COMPONENTS WHEN ENGINE MUST BE DISASSEMBLED FOR MACHINING

CRANKSHAFT INSPECTION

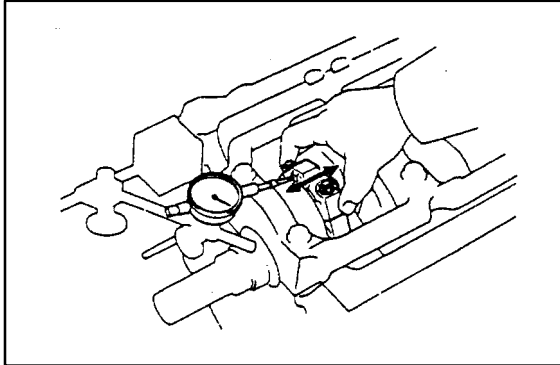

1. CHECK CONNECTING ROD THRUST CLEARANCE

- (a). Using a dial indicator, measure the thrust clearance while moving the connecting rod back and forth.

Standard thrust clearance:

0.150 – 0.330 mm (0.0059 – 0.0130 in)

Maximum thrust clearance:

0.38 mm (0.0150 in)

If the thrust clearance is greater than maximum, replace the short block assembly.

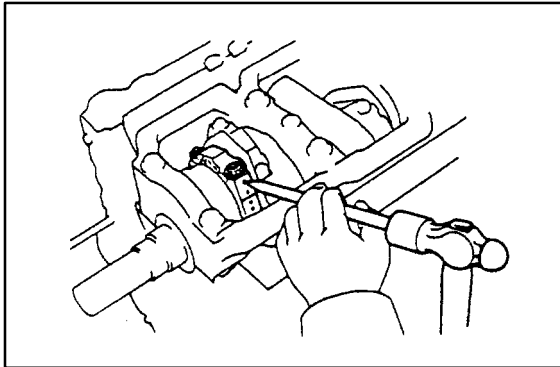

2. REMOVE CONNECTING ROD CAPS

- (a). Using a punch or numbering stamp, mark the connecting rod and cap to ensure correct reassembly.

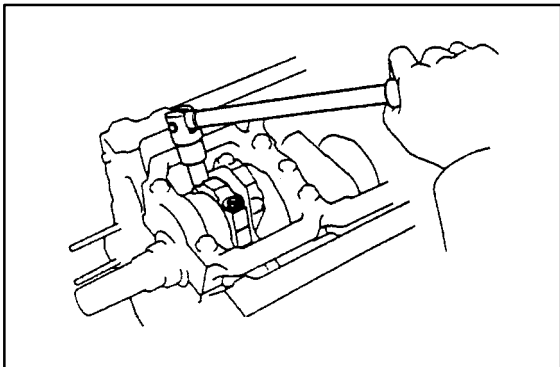

- (b). Remove the connecting rod cap nuts.

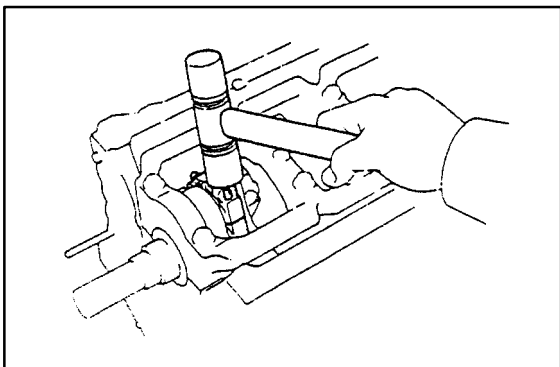

- (c). Using a plastic-faced hammer, lightly tap the connecting rod bolts and lift off the connecting rod cap.

NOTE: Keep the lower bearing inserted with the connecting rod cap.

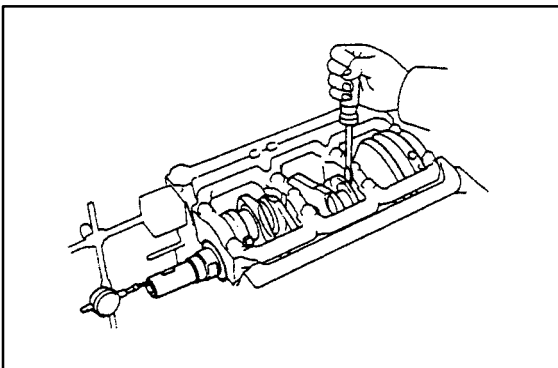
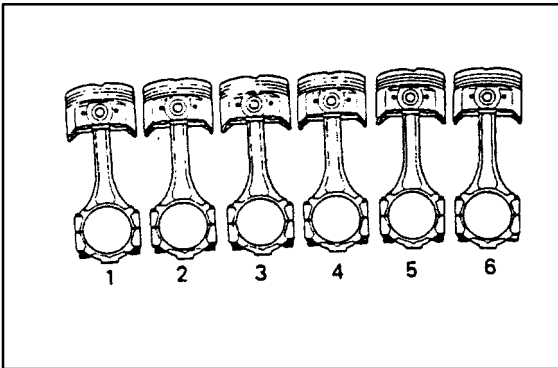
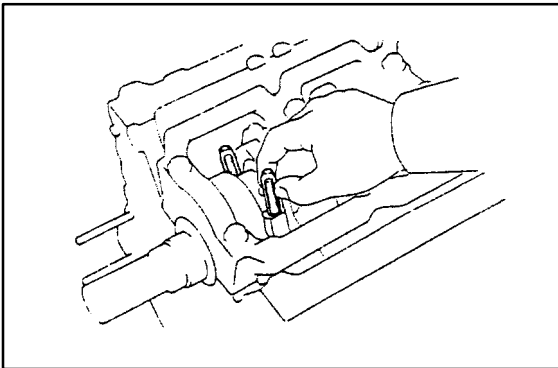
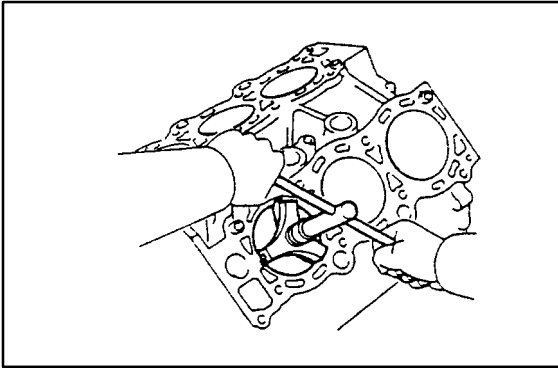

3. REMOVE PISTON AND CONNECTING ROD ASSEMBLIES

- (a). Using a ridge reamer, remove all the carbon from the top of cylinder bore.
- (b). Cover the connecting rod bolts with a short piece of hose to protect the crankshaft from damage.
- (c). Push the piston, connecting rod assembly and upper bearing through the top of the cylinder block.

NOTE:

- Keep the bearings, connecting rod and cap together.
- Arrange the piston and connecting rod assemblies in correct order.

4. CHECK CRANKSHAFT THRUST CLEARANCE

- (a). Using a dial indicator, measure the thrust clearance while prying the crankshaft back and forth with a screwdriver.

Standard thrust clearance:

0.020 – 0.220 mm (0.0008 – 0.0087 in)

Maximum thrust clearance:

0.30 mm (0.0118 in)

If the thrust clearance is greater than maximum, replace the thrust washers as a set.

Thrust washer thickness:

2.440 – 2.490 mm (0.0961 – 0.0980 in)

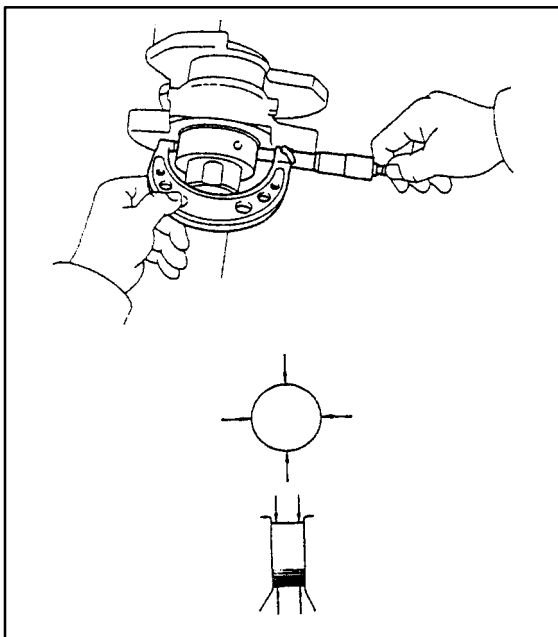
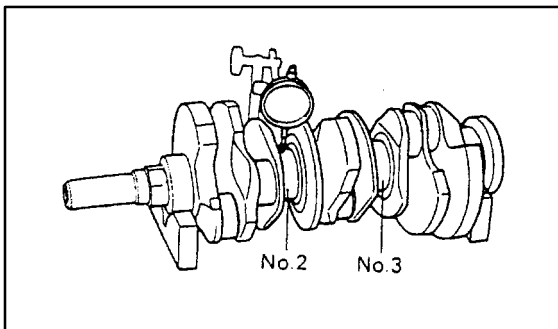
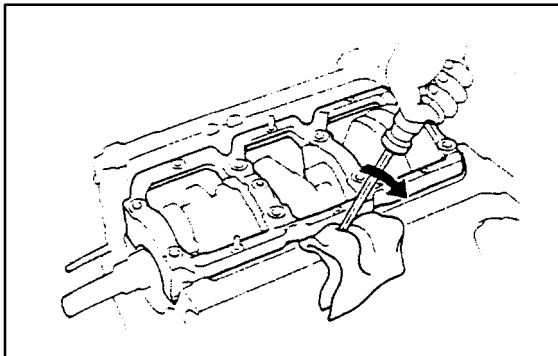
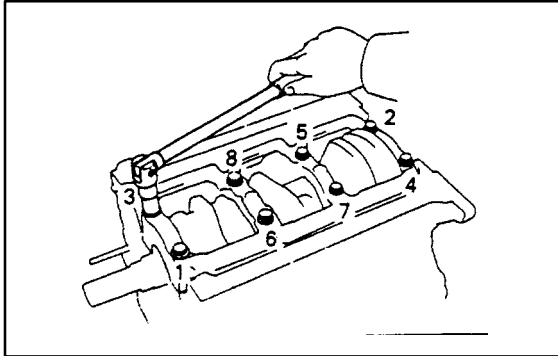

5. REMOVE MAIN BEARING CAP

- (a). Uniformly loosen and remove the main bearing cap bolts in several passes, in the sequence shown.
- (b). Using a screwdriver, pry up the main bearing cap, and remove the main bearing cap, lower main bearings and lower thrust washers (No.2 journal position of main bearing cap only).

NOTE: Keep the lower main bearings and lower thrust washers together with the main bearing cap.

- (c). Lift out the crankshaft.

NOTE: Keep the upper main bearings and upper thrust washers together with the cylinder block.

6. INSPECT CRANKSHAFT FOR RUNOUT

- (a). Place the crankshaft on V – blocks.
- (b). Using a dial indicator, measure the circle runout at the No.2 and No.3 journals.

Maximum circle runout:

0.06mm (0.0024 in)

If the circle runout is greater than maximum, replace the short block assembly.

7. INSPECT MAIN JOURNALS AND CRANK PINS

- (a). Using a micrometer, measure the diameter of each main journal and crank pin.

Main journal diameter:

STD: 64.000 mm (2.5191 – 2.5197 in)

Crank pin diameter:

STD: 55.000 mm (2.1648 – 2.1654 in)

If the diameter is not as specified, replace the short block assembly.

- (b). Check each main journal and crank pin for taper and out-of-round as shown.

Maximum taper and out-of-round:

0.02 mm (0.0008 in)

If the taper or out-of-round is greater than maximum, replace the short block assembly.

3VZ-E Cylinder Head/Block Inspection

Page 9

When reassembling the engine selectively fit the crankshaft bearings according to the numbers marked on the crankshaft, block and connecting rods.

NOTE: If using a standard bearing, replace with one having the same number. If the number of the bearing cannot be determined, select the correct bearing by adding together the numbers imprinted on the cylinder block and crankshaft, then selecting the bearing with the same number as the total. There are five sizes of standard bearings, marked "1," "2," "3," "4," and "5," accordingly.

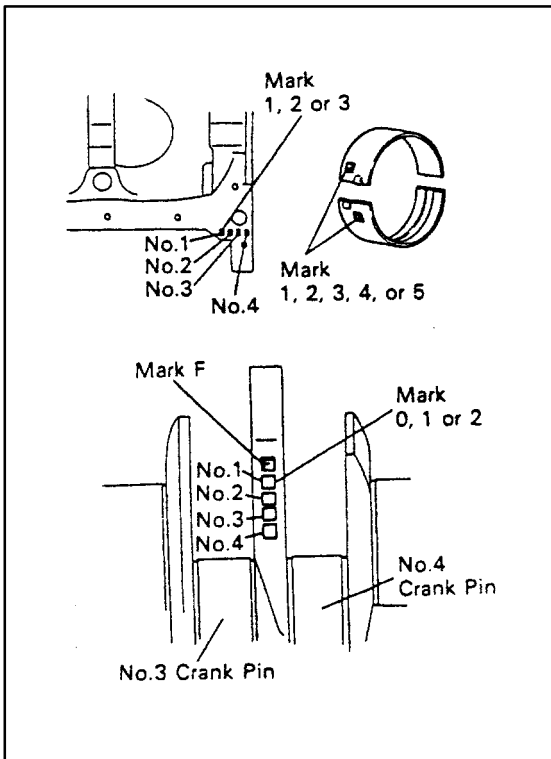

	Number marked								
	1			2			3		
Cylinder block									
Crankshaft	0	1	2	0	1	2	0	1	2
Use bearing	1	2	3	2	3	4	3	4	5

EXAMPLE: Cylinder block "2" + Crankshaft "1"
= Total number 3 (Use bearing "3")

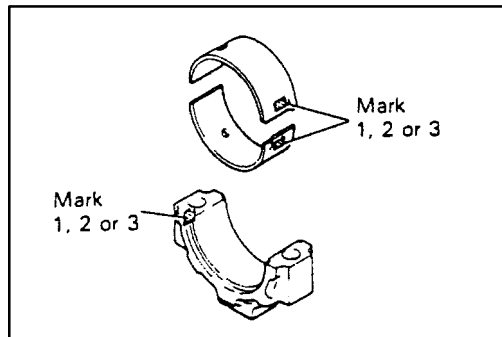

3VZ-E Cylinder Head/Block Inspection

Page 10

MACHINING INSTRUCTIONS

If the crankshaft connecting rods and pistons are serviceable and the cylinder block is not warped or eroded beyond specification, the block cylinder head surface may be machined.

In order to perform this machining operation correctly, equipment that will produce a smooth, flat, and scratch free surface must be utilized. In addition, this machine must be capable of accurately measuring the amount of material that is being removed. Following this machining operation the amount of material that has been removed must be indicated on the cylinder head and/or block by stamping the end surface as indicated.

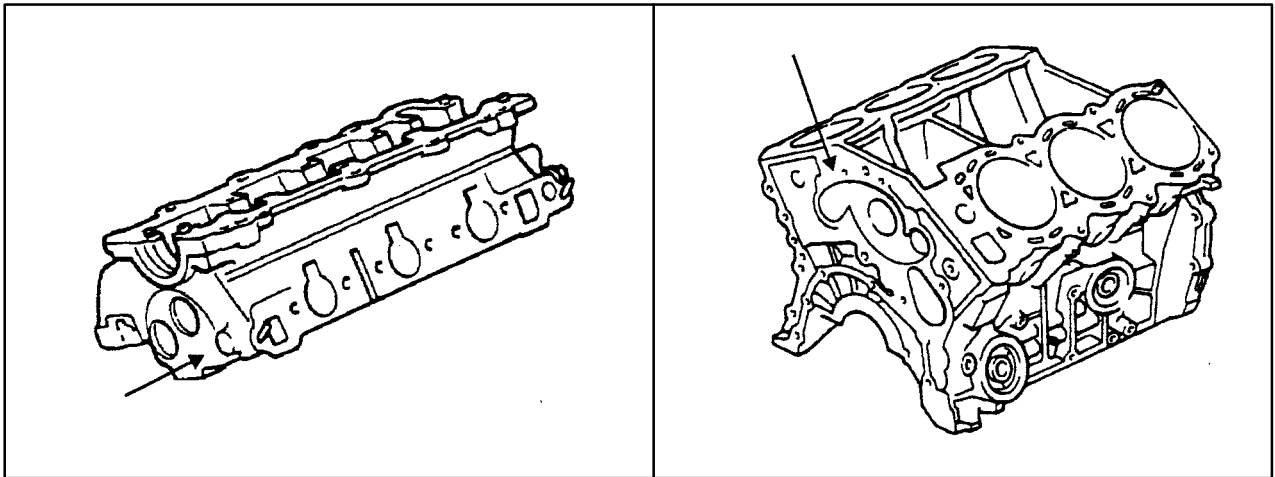

If you are uncertain as to whether or not a cylinder head or block has previously been machined, confirm the measurement of the head and/or block using the dimensions provided below.

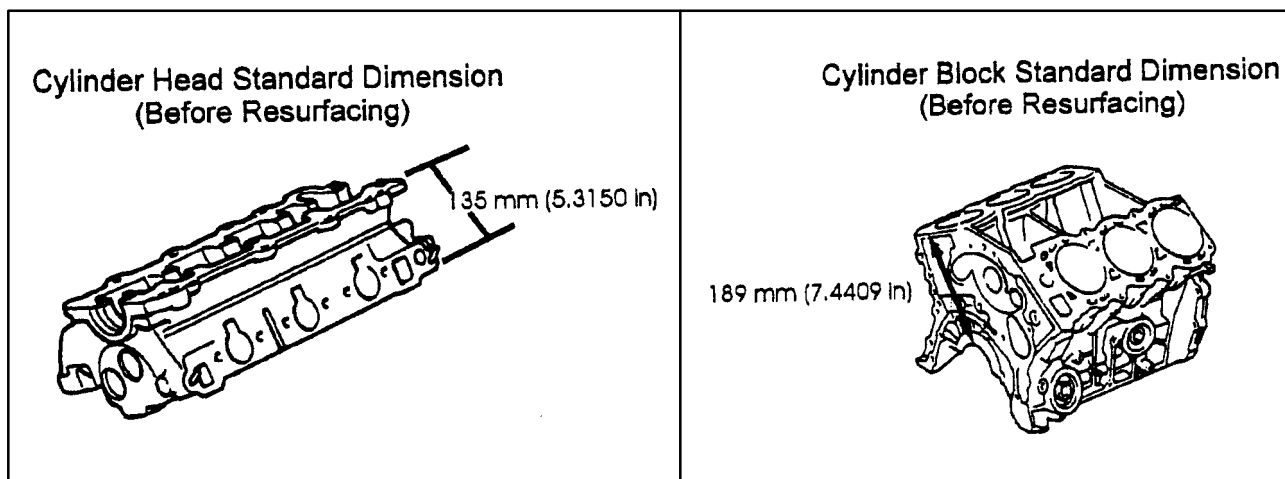

Always thoroughly clean a head or block that has been machined to ensure that all residue from the machining operation is completely removed.